



# TRAK™ 72

## POWER & EFFICIENCY

---

**Input Power Options:** 220v - 240v; 50Hz and 60Hz

**Current at Max Speed:** 0.68 Amps

**Power:** 125 W

**Maximum Speed:** 8 mph | 3.58 m/s

**Maximum Affected Area:** 24 ft. (7.32m) diameter / 576 sq. ft. (53.5m<sup>2</sup>)

## DIMENSIONS & WEIGHT

---

**Fan Diameter:** 6ft / 72 inches / 1.82m

**Fan Weight:** 48 lbs / 21.77 kilos

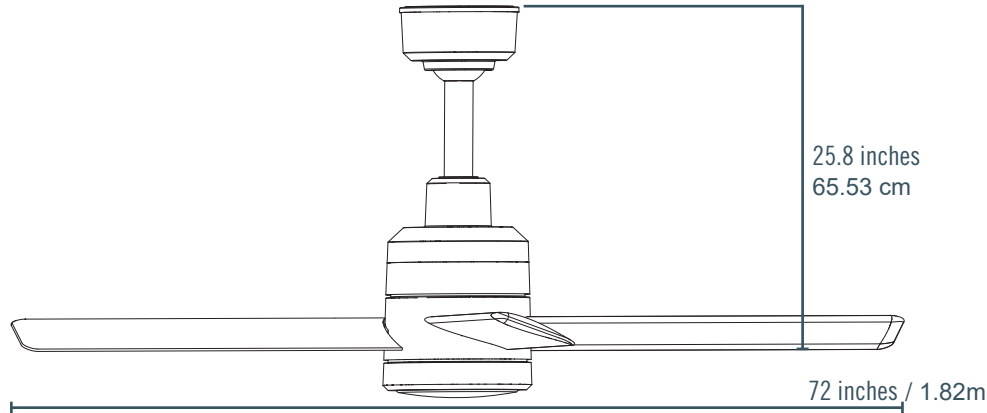

## MOUNTING & SAFETY

---

**Mounting Options:** Standard / Angled

**Downrod:** 11 inches / 27.94 cm Downrod

**Safety Features:** safety motor wire harness

## INCLUDED IN THE BOX

---

**Included:** Handheld remote control & wall platform, 11 inches / 27.94 cm Downrod

**Optional:** Handheld Control

Down Rod Sizes: 24" (61cm), 36"(91cm), 48"(121cm) , 60" (152cm), 72" (182cm)

## WARRANTY & CERTIFICATIONS

---

**Certifications:** ETL/Intertek-certified to ANSI/UL 506 and CSA C22.2 No. 113 in North America International Low Voltage Directive: 2014/35/EU. IEC / EMC / CE

**Indoor/Outdoor/Damp Rating:** IP45

**Warranty<sup>1</sup>:** 3-Year Warranty on Parts