



TRAK™ 60

POWER & EFFICIENCY

Input Power Options: 220v - 240v; 50Hz and 60Hz

Current at Max Speed: 0.52 Amps

Power: 75W

Maximum Speed: 8 mph | 3.58 m/s

Maximum Affected Area: 20 ft. (6m) diameter / 400 sq. ft. (37 m²)

DIMENSIONS & WEIGHT

Fan Diameter: 5ft / 60 inches / 1.52m

Fan Weight: 48 lbs / 21.77 kilos

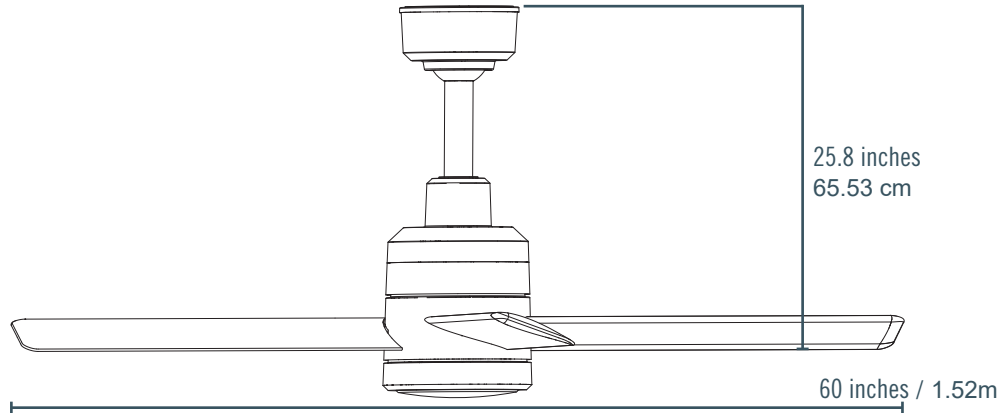

MOUNTING & SAFETY

Mounting Options: Standard / Angled

Downrod: 11 inches / 27.94 cm Downrod

Safety Features: safety motor wire harness

INCLUDED IN THE BOX

Included: handheld remote control & wall platform, 11 inches / 27.94 cm Downrod

Optional: Down Rod Sizes: 24" (61cm), 36"(91cm), 48"(121cm) , 60" (152cm), 72" (182cm)

WARRANTY & CERTIFICATIONS

Certifications: ETL/Intertek-certified to ANSI/UL 506 and CSA C22.2 No. 113 in North America International Low Voltage Directive: 2014/35/EU. IEC / EMC / CE

Indoor/Outdoor/Damp Rating: IP45

Warranty¹: 3-Year Warranty on Parts

MODELS
76042-Black
76043-White
76044-Silver